



Features

- ◆ Φ100mm standard gauge installation
- ◆ 4 digit LED display, no indication error
- ◆ 4-20mA signal output, on-site control point setting
- ◆ Two way relay control output 220 3A
- ◆ Special diaphragm coating
- ◆ Accuracy: 0.5% FS

Product Description

This series of products is designed for pressure measurement in high temperature environment. It adopts on-site LED display without indication error, two way relay output, stable work performance at 400 °C. It uses standard thread connection and is characterized by high stability and long service life.

Technical Parameters

Items	Technical Parameters
Pressure Range	0 ~ 3.5MPa or 0 ~ 200MPa
Combined Accuracy	±0.5%
Diaphragm Material	17-4 PH with anti-abrasive coating, other coating available
Overload Capacity	1.5 times rated pressure
Display Method	0.56" Nixie Tube
Indication Range	-1999 ~ 9999
Signal Output	4-20mA with two way relay output
Power Supply	24VDC/220VAC
Process Connection	1/2-20UNF、 M14×1.5、 M18×1.5、 M22×1.5
Response Time	< 30mS
Diaphragm Temp	400°C
Electrical Temp.	-20°C ~ 70°C
Temp. Drift	0.03bar/°C
I.P Grade	IP65
Mounting Torque	Max.40N.m
RH	≤80%
Temp.Measurement	J type TC, K type TC, E type TC, Pt100 RTD



Ordering Guide

Serial No	PG	X	X	X	X	X	X	X	X	X	X	X	X
Product Type	Rigid Stem	112X											
	Flexible type	123X											
	Dual Pressure&Temp Type	133X											
Pressure Range	35bar 500psi		5C										
	50bar 750psi		7.5C										
	70bar 1000psi		1M										
	100Bar 1500psi		1.5M										
	200bar 3000psi		3M										
	350bar 5000psi		5M										
	500bar 7500psi		7.5M										
	700bar 10000psi		10M										
	1000bar 15000psi		15M										
	1400bar 20000psi		20M										
2000bar 30000psi		30M											
Process Connection	1/2"-20UNF		1/2										
	M14×1.5		M14										
	M18×1.5		M18										
	M22X1.5		M22										
Rigid Stem	6 inch (152mm)				6								
	9 inch (229mm)				9								
	12.5 inch (318mm)				12								
	15 inch (381mm)				15								
	18 inch (460mm)				18								
Flexible Stem	18 inch (460mm)					/18							
	24 inch (610mm)					/24							
	30 inch (460mm)					/30							
Thermocouple	No TC						-						
	J Type						J						
	K Type						K						
	E Type						E						
	Rt100						RTD1						
Power	220VAC							V1					
	24VDC							V2					
Diaphragm	17-4PH(Standard)										-		
	Hastelloy(Anti-corrosive type)										C2		
	Inconel718(Anti-abrasive)										I7		
Filled Media	Standard											-	
	Environmentally Friendly Alloy Filled											EP	
Relay Output	Relay Output												RE
	No Relay Output												-



External Size

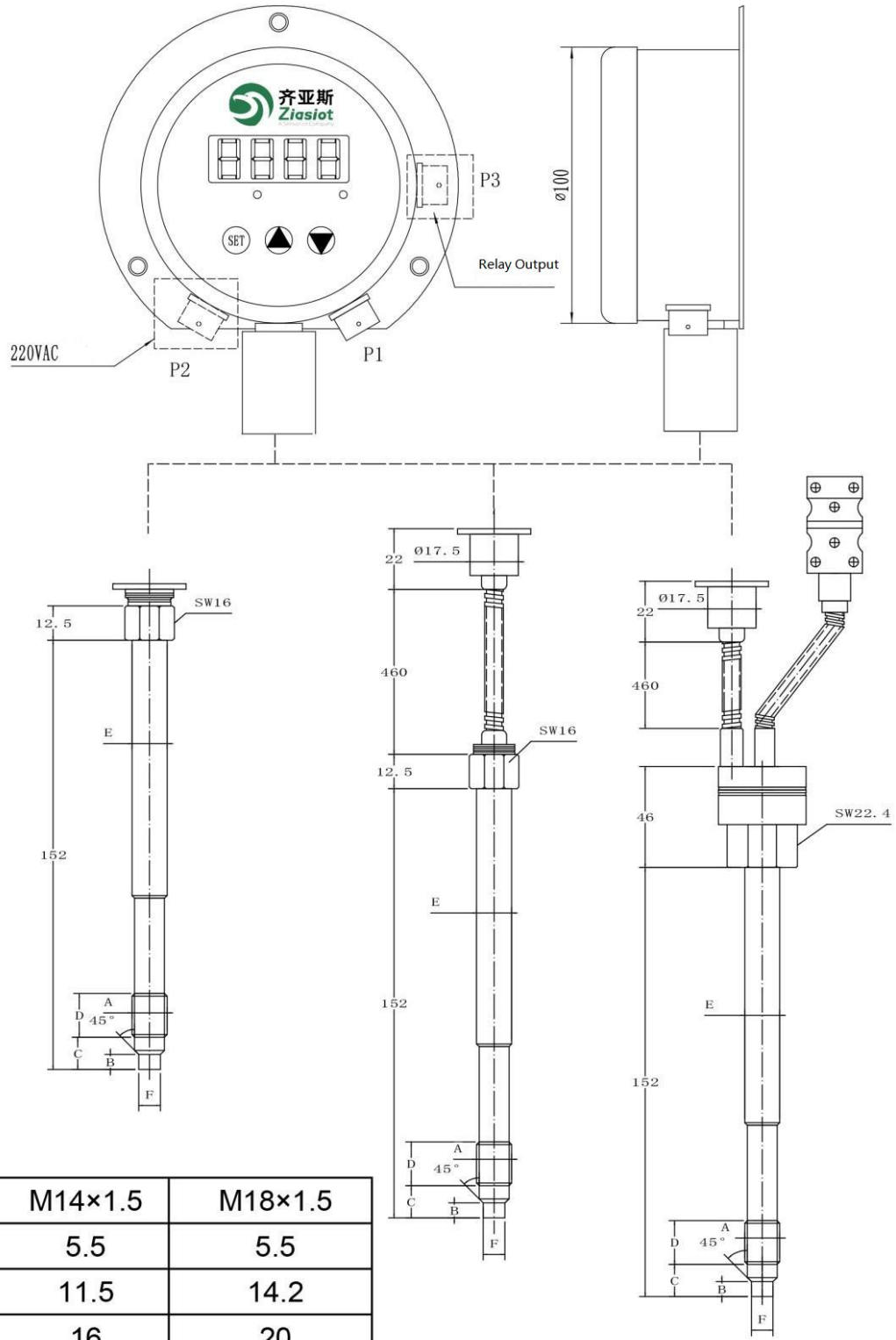

A	1/2-20UNF	M14×1.5	M18×1.5
B	5.5	5.5	5.5
C	11.5	11.5	14.2
D	16	16	20
E	Φ12.7	Φ12.7	Φ12.7
F	Φ7.8 _{-0.06}	Φ7.8 _{-0.06}	Φ9.8 _{-0.06}



Hole Size

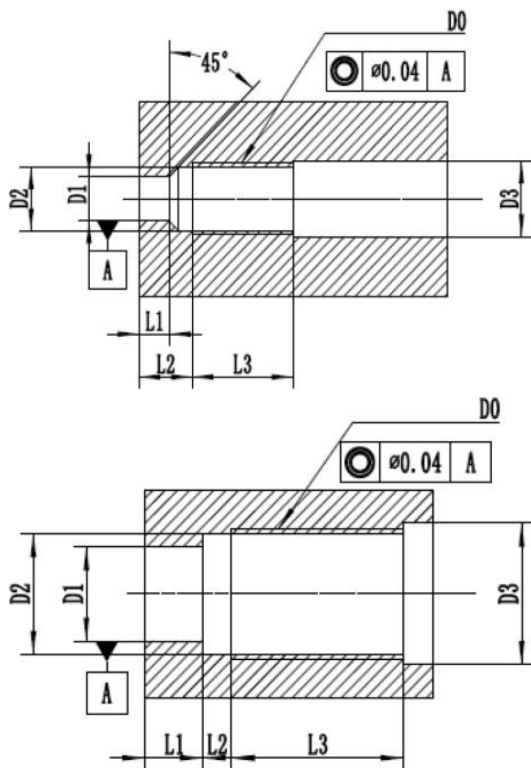

D0	1/2-20UNF	M14×1.5	M18×1.5	M12×1.5
D1	Φ8	Φ8	Φ10	Φ8
D2	Φ11.5	Φ12.5	Φ16.5	Φ10.4
D3	Φ13.5	Φ14.5	Φ20	Φ12.5
L1	5.8	5.8	5.8	5.8
L2	10	10	11	10
L3	19	19	25	19

D0	M22×1.5	M20×1.5	G3/4	G3/8
D1	Φ16.2	Φ14	Φ18	Φ10
D2	Φ20.5	Φ18.7	Φ24.5	Φ15
D3	Φ24	Φ22	Φ28	Φ18
L1	10	5.8	12	9
L2	5	3	5	4
L3	40	35	35	25

E-Connection

24VDC				
E-connection	Code	Terminal	Definition	Wire color
	P1	1	Signal+	Blue
		2	Power+	Red
		3	Signal-	White
		4	Power-	Yellow

24VDC				
E-connection	Code	Terminal	Definition	Wire color
	P1	2	Power L	Red
		4	Power N	Yellow
	P2	1	Signal+	Blue
		3	Signal -	White

Relay Output				
E-connection	Code	Terminal	Definition	Wire color
	AL-1	1		Green
		2		Red
		3		Yellow
	AL-2	4		Black
		5		Grey
		6		White



Instructions

Parameter Settings

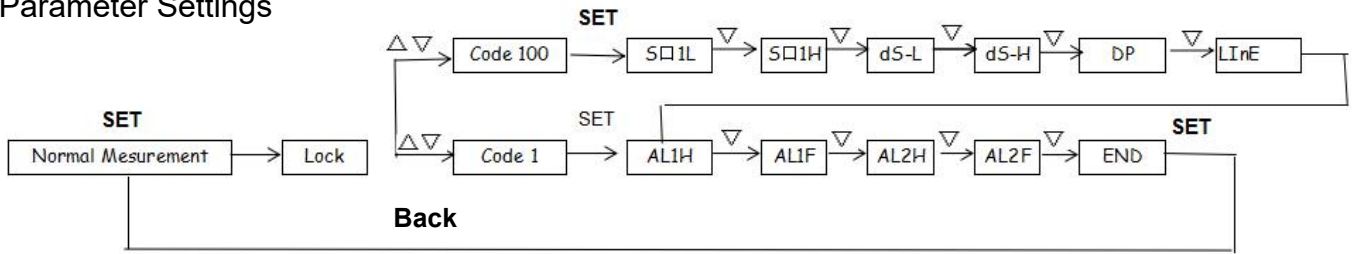

So1L transmits the zero AD value.

The meter transmits the output value when the sensor is at the zero position, press ▲ or modify the setting, subject to current or voltage output requirements. Press SET to confirm.

So1H transmits full-scale AD value

ds-L displays the zero position.

Subject to output requirements,press SET to confirm

When the instrument is at the sensor zero position, the display value and zero adjustment value, press ▲ or modify the setting, the data modification range is between -1999~+9999. Press SET to confirm, and the next menu “ds-H” will be displayed at the same time

ds-H displays full scale.

To display the value and adjust the full-scale value of the meter when the sensor is full-scale, press ▲ or modify the setting. The data modification range is between -1999~ ±9999. Press SET to confirm, and the next menu "bs1L" is displayed

Dp number of points(For general product,only set 1 digit)

LinE linear correction

AL1H This value is relay 1 Release Value

AL1F This value is relay 1 Release Value

AL2H This value is relay 2 Release Value

AL2F This value is relay 2 Release Value

Note: The switch point is determined by the configuration of the pull-in value and the release value. When the pull-in value is larger than the release value, it is the upper limit alarm output (normally open function), and when the pull-in value is smaller than the release value, it is the lower limit alarm output (normally closed function). The difference between the pull-in value and the release value is the hysteresis of the switching point.

Example: To set switch point 1 as the upper limit alarm output (normally open function) at 4Mpa, and disconnect lower than 3.95Mpa; switch point 2 is the lower limit alarm output (normally closed function) to disconnect at 10Mpa, lower than 9.95Mpa Suck

Enter the menu: set AL1H=4.00 AL1F=3.95 AL2H=9.95 AL1F=10.00

In the END menu, press the "SET" key to exit.

If there is no operation for 30 seconds in the setting state, and the menu does not exit. Then it automatically exits the setting state, but does not save the modified data. Press the key ▲ long time to set Zero-clearing function

